

# Roxtec S frame



**GB** Roxtec S frame is a metal frame available with a single opening, or in combinations with several openings in width and/or height.

- For use with Group RM components
- Attachment by welding
- SE PPS accessory available for plastic pipe seals

**CN** Roxtec S 型框架为主要用于焊接安装金属框架。提供单一开口，或在宽度方向和/或高度方向几个开口的组合。

- 适用于 RM 组件
- 焊接安装
- 提供塑料管线密封 (SE PPS) 附件

**DE** Der Roxtec S-Rahmen ist ein Metallrahmen. Erhältlich als Einzelrahmen mit nur einer Öffnung oder als Rahmenkombination in horizontaler und/oder vertikaler Anordnung.

- Zur Verwendung mit Komponenten der Gruppe RM
- Schweißmontage
- Kunststoffrohrdichtung (SE PPS) als Zubehör erhältlich

**ES** El marco S de Roxtec es un marco metálico de adhesión principalmente mediante soldadura. Disponible con una única abertura o en combinaciones con varias aberturas en anchura y/o altura.

- Uso con componentes del grupo RM
- Adhesión por soldadura
- Accesorio de sellado para tuberías de plástico (SE PPS) disponible

**FR** Le cadre S Roxtec est un cadre métallique disponible avec ouvertures uniques ou en association avec différentes largeurs et/ou hauteurs d'ouverture.





- Pour composants du Groupe RM
- Fixation par soudage
- Accessoire de soudure de tuyau plastique SE PPS disponible

# S frames, primed, mild steel

S型框架，优质低碳钢 S-Rahmen, grundierter Baustahl Marcos S en acero dulce imprimado Cadres S, acier doux peint



S 6x1 primed

Parts needed for a complete solution				Optional
				
page 22	page 137	page 141	page 145	page 146

See also Installation guidelines on page 203.

For information about other frame combinations that are not presented and for openable versions of this frame, please contact your local Roxtec supplier or e-mail: [info@roxtec.com](mailto:info@roxtec.com)

<b>RATINGS</b>	<b>Fire:</b> A-Class, H-Class	<b>Water pressure:</b> 4 bar	<b>Gas pressure:</b> 2.5 bar
----------------	-------------------------------	------------------------------	------------------------------

	框架 开孔数量	密封空间 (毫米)	外部尺寸 (D=60 毫米)		重量		货号
			HxW (毫米)	HxW (英寸)	(千克)	(磅)	
<b>CN</b>	框架						
<b>DE</b>	Rahmen	Rahmenöffnungen	Außenmaße (D=60 mm)		Gewicht		Art.-Nr.
<b>ES</b>	Marco	Aberturas del marco	Dim. externas (D=60 mm)		Peso		Nº art.
<b>FR</b>	Cadre	Nombre d'alvéoles	Dim. extérieures (D=60 mm)		Poids		Nº d'article
<b>GB</b>	Frame	Frame openings	External dimensions (D=60 mm)		Weight		Art. No.
					(kg)	(lb)	
	<b>S 1x1 primed</b>	1	60 x 60	121 x 80	4.764 x 3.150	1.6   3.527	<b>SS01000000112</b>
	<b>S 2x1 primed</b>	1	60 x 120	121 x 141	4.764 x 5.551	2.2   4.938	<b>S002000000112</b>
	<b>S 2x2 primed</b>	2	60 x 120	121 x 271	4.764 x 10.669	3.9   8.488	<b>S002000000212</b>
	<b>S 2x3 primed</b>	3	60 x 120	121 x 402	4.764 x 15.827	5.5   12.037	<b>S002000000312</b>
	<b>S 2x4 primed</b>	4	60 x 120	121 x 532	4.764 x 20.945	7.1   15.609	<b>S002000000412</b>
	<b>S 2x5 primed</b>	5	60 x 120	121 x 663	4.764 x 26.102	8.7   19.158	<b>S002000000512</b>
	<b>S 2x6 primed</b>	6	60 x 120	121 x 793	4.764 x 31.220	10.3   22.707	<b>S002000000612</b>
	<b>S 3x1 primed</b>	1	120 x 60	180 x 80	7.087 x 3.150	2.3   5.071	<b>SS03000000112</b>
	<b>S 4x1 primed</b>	1	120 x 120	180 x 141	7.087 x 5.551	2.8   6.151	<b>S004000000112</b>
	<b>S 4x2 primed</b>	2	120 x 120	180 x 271	7.087 x 10.669	4.7   10.318	<b>S004000000212</b>
	<b>S 4x3 primed</b>	3	120 x 120	180 x 402	7.087 x 15.827	6.6   14.484	<b>S004000000312</b>
	<b>S 4x4 primed</b>	4	120 x 120	180 x 532	7.087 x 20.945	8.5   18.629	<b>S004000000412</b>
	<b>S 4x5 primed</b>	5	120 x 120	180 x 663	7.087 x 26.102	10.3   22.796	<b>S004000000512</b>
	<b>S 4x6 primed</b>	6	120 x 120	180 x 793	7.087 x 31.220	12.2   26.962	<b>S004000000612</b>
	<b>S 4x7 primed</b>	7	120 x 120	180 x 924	7.087 x 36.378	14.1   31.129	<b>S004000000712</b>
	<b>S 4x8 primed</b>	8	120 x 120	180 x 1054	7.087 x 41.496	16.0   35.296	<b>S004000000812</b>
	<b>S 4x9 primed</b>	9	120 x 120	180 x 1185	7.087 x 46.654	17.9   39.440	<b>S004000000912</b>

## S frames, primed, mild steel

S型框架, 优质低碳钢 S-Rahmen, grundierter Baustahl Marcos S en acero dulce imprimado Cadres S, acier doux peint

CN	框架	框架 开孔数量	密封空间 (毫米)	外部尺寸 (D=60 毫米)		重量		货号
	DE	Rahmen- öffnungen	Belegraum (mm)	HxW (毫米)	HxW (英寸)	(千克)	(磅)	Art.-Nr.
ES	Marco	Aberturas del marco	Espacio útil de sellado (mm)	Dim. externas (D=60 mm)		Peso		Nº art.
FR	Cadre	Nombre d'alvéoles	Espace de remplissage (mm)	Dim. extérieures (D=60 mm)		Poids		Nº d'article
GB	Frame	Frame openings	Packing space (mm)	External dimensions (D=60 mm)		Weight		Art. No.
				HxW (mm)	HxW (in.)	(kg)	(lb)	
	<b>S 4+4x1 primed</b>	2	120 x 120	349 x 141	13.740 x 5.551	5.0	11.067	<b>S004400000112</b>
	<b>S 4+4x2 primed</b>	4	120 x 120	359 x 271	14.134 x 10.669	9.5	20.878	<b>S004400000212</b>
	<b>S 4+4x3 primed</b>	6	120 x 120	359 x 402	14.134 x 15.827	13.5	29.321	<b>S004400000312</b>
	<b>S 4+4x4 primed</b>	8	120 x 120	359 x 532	14.134 x 20.945	17.1	37.743	<b>S004400000412</b>
	<b>S 4+4x5 primed</b>	10	120 x 120	359 x 663	14.134 x 26.102	21.0	46.186	<b>S004400000512</b>
	<b>S 4+4x6 primed</b>	12	120 x 120	359 x 793	14.134 x 31.220	24.8	54.630	<b>S004400000612</b>
	<b>S 4+4x7 primed</b>	14	120 x 120	359 x 924	14.134 x 36.378	28.6	63.096	<b>S004400000712</b>
	<b>S 4+4x8 primed</b>	16	120 x 120	359 x 1054	14.134 x 41.496	32.6	71.539	<b>S004400000812</b>
	<b>S 4+4+4x1 primed</b>	3	120 x 120	519 x 141	20.433 x 5.551	6.6	14.550	<b>S004440000112</b>
	<b>S 4+4+4x2 primed</b>	6	120 x 120	539 x 271	21.220 x 10.669	14.2	31.305	<b>S004440000212</b>
	<b>S 4+4+4x3 primed</b>	9	120 x 120	539 x 402	21.220 x 15.827	19.9	43.872	<b>S004440000312</b>
	<b>S 4+4+4x4 primed</b>	12	120 x 120	539 x 532	21.220 x 20.945	26.2	57.761	<b>S004440000412</b>
	<b>S 4+4+4x5 primed</b>	15	120 x 120	539 x 663	21.220 x 26.102	31.3	69.004	<b>S004440000512</b>
	<b>S 4+4+4x6 primed</b>	18	120 x 120	539 x 793	21.220 x 31.220	37.0	81.570	<b>S004440000612</b>
	<b>S 5x1 primed</b>	1	180 x 60	238 x 80	9.370 x 3.150	2.8	6.173	<b>SS05000000112</b>
	<b>S 6x1 primed</b>	1	180 x 120	238 x 141	9.370 x 5.551	3.3	7.363	<b>S006000000112</b>
	<b>S 6x2 primed</b>	2	180 x 120	238 x 271	9.370 x 10.669	5.5	12.147	<b>S006000000212</b>
	<b>S 6x3 primed</b>	3	180 x 120	238 x 402	9.370 x 15.827	7.7	16.909	<b>S006000000312</b>
	<b>S 6x4 primed</b>	4	180 x 120	238 x 532	9.370 x 20.945	9.8	21.671	<b>S006000000412</b>
	<b>S 6x5 primed</b>	5	180 x 120	238 x 663	9.370 x 26.102	12.0	26.455	<b>S006000000512</b>
	<b>S 6x6 primed</b>	6	180 x 120	238 x 793	9.370 x 31.220	14.2	31.217	<b>S006000000612</b>
	<b>S 6x7 primed</b>	7	180 x 120	238 x 924	9.370 x 36.378	16.3	35.979	<b>S006000000712</b>
	<b>S 6x8 primed</b>	8	180 x 120	238 x 1054	9.370 x 41.496	18.5	40.763	<b>S006000000812</b>
	<b>S 6x9 primed</b>	9	180 x 120	238 x 1185	9.370 x 46.654	20.7	45.525	<b>S006000000912</b>
	<b>S 6+6x1 primed</b>	2	180 x 120	466 x 141	18.346 x 5.551	6.1	13.492	<b>S006600000112</b>
	<b>S 6+6x2 primed</b>	4	180 x 120	476 x 271	18.740 x 10.669	11.1	24.537	<b>S006600000212</b>
	<b>S 6+6x3 primed</b>	6	180 x 120	476 x 402	18.740 x 15.827	15.5	34.171	<b>S006600000312</b>
	<b>S 6+6x4 primed</b>	8	180 x 120	476 x 532	18.740 x 20.945	19.9	43.827	<b>S006600000412</b>
	<b>S 6+6x5 primed</b>	10	180 x 120	476 x 663	18.740 x 26.102	24.3	53.506	<b>S006600000512</b>

## S frames, primed, mild steel

S型框架, 优质低碳钢 S-Rahmen, grundierter Baustahl Marcos S en acero dulce imprimado Cadres S, acier doux peint

CN	框架	框架 开孔数量	密封空间 (毫米)	外部尺寸 (D=60 毫米)		重量		货号
				HxW (毫米)	HxW (英寸)	(千克)	(磅)	
DE	Rahmen	Rahmen- öffnungen	Belegraum (mm)	Außenmaße (D=60 mm)		Gewicht		Art.-Nr.
ES	Marco	Aberturas del marco	Espacio útil de sellado (mm)	Dim. externas (D=60 mm)		Peso		Nº art.
FR	Cadre	Nombre d'alvéoles	Espace de remplissage (mm)	Dim. extérieures (D=60 mm)		Poids		Nº d'article
GB	Frame	Frame openings	Packing space (mm)	External dimensions (D=60 mm)		Weight		Art. No.
				HxW (mm)	HxW (in.)	(kg)	(lb)	
	<b>S 6+6x6 primed</b>	12	180 x 120	476 x 793	18.740 x 31.220	28.6	63.140	<b>S006600000612</b>
	<b>S 6+6x7 primed</b>	14	180 x 120	476 x 924	18.740 x 36.378	33.0	72.796	<b>S006600000712</b>
	<b>S 6+6x8 primed</b>	16	180 x 120	476 x 1054	18.740 x 41.496	37.4	82.474	<b>S006600000812</b>
	<b>S 6+6x9 primed</b>	18	180 x 120	476 x 1185	18.740 x 46.654	41.8	92.108	<b>S006600000912</b>
	<b>S 6+6x10 primed</b>	20	180 x 120	476 x 1315	18.740 x 51.772	46.2	101.764	<b>S006600001012</b>
	<b>S 6+6+6x1 primed</b>	3	180 x 120	694 x 141	27.323 x 5.551	8.2	18.078	<b>S006660000112</b>
	<b>S 7x1 primed</b>	1	240 x 60	298 x 80	11.732 x 3.150	3.3	7.363	<b>SS07000000112</b>
	<b>S 8x1 primed</b>	1	240 x 120	298 x 141	11.732 x 5.551	3.9	8.620	<b>S008000000112</b>
	<b>S 8x2 primed</b>	2	240 x 120	298 x 271	11.732 x 10.669	6.1	13.382	<b>S008000000212</b>
	<b>S 8x3 primed</b>	3	240 x 120	298 x 402	11.732 x 15.827	8.2	18.144	<b>S008000000312</b>
	<b>S 8x4 primed</b>	4	240 x 120	298 x 532	11.732 x 20.945	10.4	22.928	<b>S008000000412</b>
	<b>S 8x5 primed</b>	5	240 x 120	298 x 663	11.732 x 26.102	12.6	27.690	<b>S008000000512</b>
	<b>S 8x6 primed</b>	6	240 x 120	298 x 793	11.732 x 31.220	14.7	32.452	<b>S008000000612</b>
	<b>S 8+8x1 primed</b>	2	240 x 120	586 x 141	23.071 x 5.551	7.3	16.005	<b>S008800000112</b>
	<b>S 8+8x2 primed</b>	4	240 x 120	596 x 271	23.465 x 10.669	12.3	27.006	<b>S008800000212</b>
	<b>S 8+8x3 primed</b>	6	240 x 120	596 x 402	23.465 x 15.827	16.6	36.640	<b>S008800000312</b>
	<b>S 8+8x4 primed</b>	8	240 x 120	596 x 532	23.465 x 20.945	21.0	46.341	<b>S008800000412</b>
	<b>S 8+8x5 primed</b>	10	240 x 120	596 x 663	23.465 x 26.102	25.4	55.975	<b>S008800000512</b>
	<b>S 8+8x6 primed</b>	12	240 x 120	596 x 793	23.465 x 31.220	29.8	65.609	<b>S008800000612</b>
	<b>S 8+8x7 primed</b>	14	240 x 120	596 x 924	23.465 x 36.378	34.2	75.309	<b>S008800000712</b>
	<b>S 8+8x8 primed</b>	16	240 x 120	596 x 1054	23.465 x 41.496	38.5	84.943	<b>S008800000812</b>
	<b>S 8+8x9 primed</b>	18	240 x 120	596 x 1185	23.465 x 46.654	42.9	94.577	<b>S008800000912</b>
	<b>S 8+8x10 primed</b>	20	240 x 120	596 x 1315	23.465 x 51.772	47.3	104.278	<b>S008800001012</b>
	<b>S 8+8+8x1 primed</b>	3	240 x 120	874 x 141	34.409 x 5.551	9.9	21.826	<b>S008880000112</b>

## S frames, acid proof stainless steel

S型框架，耐酸不锈钢】S-Rahmen, säurefester, rostfreier Edelstahl】Marcos S en acero inoxidable a prueba de ácidos】  
Cadres S, acier inoxydable résistant aux acides



S 6x1 AISI 316

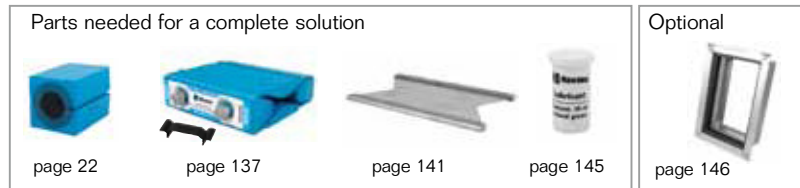

See also Installation guidelines on page 203.

For information about other frame combinations that are not presented and for openable versions of this frame, please contact your local Roxtec supplier or e-mail: [info@roxtec.com](mailto:info@roxtec.com)

<b>RATINGS</b>	<b>Fire:</b> A-Class, H-Class	<b>Water pressure:</b> 4 bar	<b>Gas pressure:</b> 2.5 bar
----------------	-------------------------------	------------------------------	------------------------------

	CN 框架	DE Rahmen	ES Marco	FR Cadre	GB Frame	框架 开孔数量	密封空间 (毫米)	外部尺寸 (D=60 毫米)		重量		货号
								HxW (毫米)	HxW (英寸)	(千克)	(磅)	
						Rahmen- öffnungen	Belegraum (mm)	Außenmaße (D=60 mm)		Gewicht		Art.-Nr.
						Aberturas del marco	Espacio útil de sellado (mm)	Dim. externas (D=60 mm)		Peso		Nº art.
						Nombre d'alvéoles	Espace de remplissage (mm)	Dim. extérieures (D=60 mm)		Poids		Nº d'article
						Frame openings	Packing space (mm)	External dimensions (D=60 mm)		Weight		Art. No.
						S 2x1 AISI 316	60 x 120	121 x 141	4.764 x 5.551	2.2	4.938	S002000000121
						S 2x2 AISI 316	60 x 120	121 x 271	4.764 x 10.669	3.9	8.488	S002000000221
						S 2x3 AISI 316	60 x 120	121 x 402	4.764 x 15.827	5.5	12.037	S002000000321
						S 2x4 AISI 316	60 x 120	121 x 532	4.764 x 20.945	7.1	15.609	S002000000421
						S 2x5 AISI 316	60 x 120	121 x 663	4.764 x 26.102	8.7	19.158	S002000000521
						S 2x6 AISI 316	60 x 120	121 x 793	4.764 x 31.220	10.3	22.707	S002000000621
						S 4x1 AISI 316	120 x 120	180 x 141	7.087 x 5.551	2.8	6.151	S004000000121
						S 4x2 AISI 316	120 x 120	180 x 271	7.087 x 10.669	4.7	10.318	S004000000221
						S 4x3 AISI 316	120 x 120	180 x 402	7.087 x 15.827	6.6	14.484	S004000000321
						S 4x4 AISI 316	120 x 120	180 x 532	7.087 x 20.945	8.5	18.629	S004000000421
						S 4x5 AISI 316	120 x 120	180 x 663	7.087 x 26.102	10.3	22.796	S004000000521
						S 4x6 AISI 316	120 x 120	180 x 793	7.087 x 31.220	12.2	26.962	S004000000621
						S 4+4x1 AISI 316	120 x 120	349 x 141	13.740 x 5.551	5.0	11.067	S004400000121
						S 4+4+4x1 AISI 316	120 x 120	519 x 141	20.433 x 5.551	6.6	14.550	S004440000121
						S 6x1 AISI 316	180 x 120	238 x 141	9.370 x 5.551	3.3	7.363	S006000000121
						S 6x2 AISI 316	180 x 120	238 x 271	9.370 x 10.669	5.5	12.147	S006000000221

## S frames, acid proof stainless steel

S型框架，耐酸不锈钢】S-Rahmen, säurefester, rostfreier Edelstahl】Marcos S en acero inoxidable a prueba de ácidos】  
Cadres S, acier inoxydable résistant aux acides

CN	框架	框架 开孔数量	密封空间 (毫米)	外部尺寸 (D=60 毫米)		重量		货号
				HxW (毫米)	HxW (英寸)	(千克)	(磅)	
DE	Rahmen	Rahmen- öffnungen	Belegraum (mm)	Außenmaße (D=60 mm)		Gewicht		Art.-Nr.
ES	Marco	Aberturas del marco	Espacio útil de sellado (mm)	Dim. externas (D=60 mm)		Peso		Nº art.
FR	Cadre	Nombre d'alvéoles	Espace de remplissage (mm)	Dim. extérieures (D=60 mm)		Poids		Nº d'article
GB	Frame	Frame openings	Packing space (mm)	External dimensions (D=60 mm)		Weight		Art. No.
				HxW (mm)	HxW (in.)	(kg)	(lb)	
	<b>S 6x3 AISI 316</b>	3	180 x 120	238 x 402	9.370 x 15.827	7.7	16.909	<b>S006000000321</b>
	<b>S 6x4 AISI 316</b>	4	180 x 120	238 x 532	9.370 x 20.945	9.8	21.671	<b>S006000000421</b>
	<b>S 6x5 AISI 316</b>	5	180 x 120	238 x 663	9.370 x 26.102	12.0	26.455	<b>S006000000521</b>
	<b>S 6x6 AISI 316</b>	6	180 x 120	238 x 793	9.370 x 31.220	14.2	31.217	<b>S006000000621</b>
	<b>S 6+6x1 AISI 316</b>	2	180 x 120	466 x 141	18.346 x 5.551	6.1	13.492	<b>S006600000121</b>
	<b>S 6+6x2 AISI 316</b>	4	180 x 120	476 x 271	18.740 x 10.669	11.1	24.537	<b>S006600000221</b>
	<b>S 6+6x3 AISI 316</b>	6	180 x 120	476 x 402	18.740 x 15.827	15.5	34.171	<b>S006600000321</b>
	<b>S 6+6x4 AISI 316</b>	8	180 x 120	476 x 532	18.740 x 20.945	19.9	43.872	<b>S006600000421</b>
	<b>S 6+6x5 AISI 316</b>	10	180 x 120	476 x 663	18.740 x 26.102	24.3	53.506	<b>S006600000521</b>
	<b>S 6+6x6 AISI 316</b>	12	180 x 120	476 x 793	18.740 x 31.220	28.6	63.140	<b>S006600000621</b>
	<b>S 8x1 AISI 316</b>	1	240 x 120	298 x 141	11.732 x 5.551	3.9	8.620	<b>S008000000121</b>
	<b>S 8x2 AISI 316</b>	2	240 x 120	298 x 271	11.732 x 10.669	6.1	13.382	<b>S008000000221</b>
	<b>S 8x3 AISI 316</b>	3	240 x 120	298 x 402	11.732 x 15.827	8.2	18.144	<b>S008000000321</b>
	<b>S 8x4 AISI 316</b>	4	240 x 120	298 x 532	11.732 x 20.945	10.4	22.928	<b>S008000000421</b>
	<b>S 8x5 AISI 316</b>	5	240 x 120	298 x 663	11.732 x 26.102	12.6	27.690	<b>S008000000521</b>
	<b>S 8x6 AISI 316</b>	6	240 x 120	298 x 793	11.732 x 31.220	14.7	32.452	<b>S008000000621</b>
	<b>S 8+8x1 AISI 316</b>	2	240 x 120	586 x 141	23.071 x 5.551	7.3	16.005	<b>S008800000121</b>
	<b>S 8+8+8x1 AISI 316</b>	3	240 x 120	874 x 141	34.409 x 5.551	9.9	21.826	<b>S008880000121</b>

# S frames, aluminum

S型框架, 铝 S-Rahmen, Aluminium Marcos S en aluminio Cadres S aluminium



S 6x1 ALU

Parts needed for a complete solution

page 22      page 137      page 141      page 145

Optional

page 146

See also Installation guidelines on page 203.

For information about other frame combinations that are not presented and for openable versions of this frame, please contact your local Roxtec supplier or e-mail: [info@roxtec.com](mailto:info@roxtec.com)

<b>RATINGS</b>	<b>Fire:</b> A-Class, H-Class	<b>Water pressure:</b> 4 bar	<b>Gas pressure:</b> 2.5 bar
----------------	-------------------------------	------------------------------	------------------------------

	框架 Rahmen Marco Cadre Frame	框架 穿孔数量 Aberturas del marco Nombre d'alvéoles Frame openings	密封空间 (毫米) Belegraum (mm) Espacio útil de sellado (mm) Espace de remplissage (mm) Packing space (mm)	外部尺寸 (D=60 毫米) HxW (毫米)   HxW (英寸) Außenmaße (D=60 mm) HxW (mm)   HxW (in.) Dim. externas (D=60 mm) HxW (mm)   HxW (pulgadas) Dim. extérieures (D=60 mm) HxW (mm)   HxW (pouces) External dimensions (D=60 mm) HxW (mm)   HxW (in.)		重量 (千克)   (磅) Gewicht (kg)   (lb) Peso (kg)   (libra) Poids (kg)   (lb) Weight (kg)   (lb)		货号 Art.-Nr. N° art. N° d'article Art. No.
				HxW (mm)	HxW (in.)	(kg)	(lb)	
<b>CN</b>	框架	框架穿孔数量	密封空间 (毫米)	外部尺寸 (D=60 毫米) HxW (毫米)   HxW (英寸)		重量 (千克)   (磅)		货号
<b>DE</b>	Rahmen	Rahmen-öffnungen	Belegraum (mm)	Außenmaße (D=60 mm) HxW (mm)   HxW (in.)		Gewicht (kg)   (lb)		Art.-Nr.
<b>ES</b>	Marco	Aberturas del marco	Espacio útil de sellado (mm)	Dim. externas (D=60 mm) HxW (mm)   HxW (pulgadas)		Peso (kg)   (libra)		N° art.
<b>FR</b>	Cadre	Nombre d'alvéoles	Espace de remplissage (mm)	Dim. extérieures (D=60 mm) HxW (mm)   HxW (pouces)		Poids (kg)   (lb)		N° d'article
<b>GB</b>	Frame	Frame openings	Packing space (mm)	External dimensions (D=60 mm) HxW (mm)   HxW (in.)		Weight (kg)   (lb)		Art. No.
	<b>S 2x1 ALU</b>	1	60 x 120	121 x 141	4.764 x 5.551	0.8	1.698	<b>S00200000131</b>
	<b>S 2x2 ALU</b>	2	60 x 120	121 x 271	4.764 x 10.669	1.3	2.910	<b>S00200000231</b>
	<b>S 2x3 ALU</b>	3	60 x 120	121 x 402	4.764 x 15.827	1.9	4.145	<b>S00200000331</b>
	<b>S 2x4 ALU</b>	4	60 x 120	121 x 532	4.764 x 20.945	2.4	5.357	<b>S00200000431</b>
	<b>S 2x5 ALU</b>	5	60 x 120	121 x 663	4.764 x 26.102	3.0	6.592	<b>S00200000531</b>
	<b>S 2x6 ALU</b>	6	60 x 120	121 x 793	4.764 x 31.220	3.5	7.804	<b>S00200000631</b>
	<b>S 2+2x1 ALU</b>	2	60 x 120	232 x 141	9.134 x 5.551	1.3	2.965	<b>S00220000131</b>
	<b>S 2+2+2x1 ALU</b>	3	60 x 120	343 x 141	13.504 x 5.551	1.7	3.748	<b>S002220000131</b>
	<b>S 4x1 ALU</b>	1	120 x 120	180 x 141	7.087 x 5.551	1.0	2.116	<b>S004000000131</b>
	<b>S 4x2 ALU</b>	2	120 x 120	180 x 271	7.087 x 10.669	1.6	3.549	<b>S004000000231</b>
	<b>S 4x3 ALU</b>	3	120 x 120	180 x 402	7.087 x 15.827	2.3	4.982	<b>S004000000331</b>
	<b>S 4x4 ALU</b>	4	120 x 120	180 x 532	7.087 x 20.945	2.9	6.415	<b>S004000000431</b>
	<b>S 4x5 ALU</b>	5	120 x 120	180 x 663	7.087 x 26.102	3.6	7.848	<b>S004000000531</b>
	<b>S 4x6 ALU</b>	6	120 x 120	180 x 793	7.087 x 31.220	4.2	9.281	<b>S004000000631</b>
	<b>S 4+4x1 ALU</b>	2	120 x 120	349 x 141	13.740 x 5.551	1.7	3.762	<b>S004400000131</b>
	<b>S 4+4x2 ALU</b>	4	120 x 120	359 x 271	14.134 x 10.669	3.2	7.099	<b>S004400000231</b>

## S frames, aluminum

S型框架, 铝 S-Rahmen, Aluminium Marcos S en aluminio Cadres S aluminium

CN	框架	框架 开孔数量	密封空间 (毫米)	外部尺寸 (D=60 毫米)		重量		货号
				HxW (毫米)	HxW (英寸)	(千克)	(磅)	
DE	Rahmen	Rahmen- öffnungen	Belegraum (mm)	Außenmaße (D=60 mm) HxW (mm)   HxW (in.)		Gewicht (kg)   (lb)		Art.-Nr.
ES	Marco	Aberturas del marco	Espacio útil de sellado (mm)	Dim. externas (D=60 mm) HxW (mm)   HxW (pulgadas)		Peso (kg)   (libra)		Nº art.
FR	Cadre	Nombre d'alvéoles	Espace de remplissage (mm)	Dim. extérieures (D=60 mm) HxW (mm)   HxW (pouces)		Poids (kg)   (lb)		Nº d'article
GB	Frame	Frame openings	Packing space (mm)	External dimensions (D=60 mm) HxW (mm)   HxW (in)		Weight (kg)   (lb)		Art. No.
	<b>S 4+4x3 ALU</b>	6	120 x 120	359 x 402	14.134 x 15.827	4.5	9.965	<b>S004400000331</b>
	<b>S 4+4x4 ALU</b>	8	120 x 120	359 x 532	14.134 x 20.495	5.8	12.831	<b>S004400000431</b>
	<b>S 4+4+4x1 ALU</b>	3	120 x 120	519 x 141	20.433 x 5.551	2.3	5.071	<b>S004440000131</b>
	<b>S 6x1 ALU</b>	1	180 x 120	238 x 141	9.370 x 5.551	1.2	2.535	<b>S006000000131</b>
	<b>S 6x2 ALU</b>	2	180 x 120	238 x 271	9.370 x 10.669	1.9	4.167	<b>S006000000231</b>
	<b>S 6x3 ALU</b>	3	180 x 120	238 x 402	9.370 x 15.827	2.6	5.820	<b>S006000000331</b>
	<b>S 6x4 ALU</b>	4	180 x 120	238 x 532	9.370 x 20.495	3.4	7.452	<b>S006000000431</b>
	<b>S 6x5 ALU</b>	5	180 x 120	238 x 663	9.370 x 26.102	4.1	9.083	<b>S006000000531</b>
	<b>S 6x6 ALU</b>	6	180 x 120	238 x 793	9.370 x 31.220	4.9	10.736	<b>S006000000631</b>
	<b>S 6+6x1 ALU</b>	2	180 x 120	466 x 141	18.346 x 5.551	2.1	4.630	<b>S006600000131</b>
	<b>S 6+6x2 ALU</b>	4	180 x 120	476 x 271	18.740 x 10.669	3.8	8.333	<b>S006600000231</b>
	<b>S 6+6x3 ALU</b>	6	180 x 120	476 x 402	18.740 x 15.827	5.3	11.640	<b>S006600000331</b>
	<b>S 6+6x4 ALU</b>	8	180 x 120	476 x 532	18.740 x 20.495	6.8	14.903	<b>S006600000431</b>
	<b>S 6+6x5 ALU</b>	10	180 x 120	476 x 663	18.740 x 26.102	8.2	18.166	<b>S006600000531</b>
	<b>S 6+6x6 ALU</b>	12	180 x 120	476 x 793	18.740 x 31.220	9.7	21.473	<b>S006600000631</b>
	<b>S 6+6+6x1 ALU</b>	3	180 x 120	694 x 141	27.323 x 5.551	2.8	6.173	<b>S006660000131</b>
	<b>S 8x1 ALU</b>	1	240 x 120	298 x 141	11.732 x 5.551	1.3	2.954	<b>S008000000131</b>
	<b>S 8x2 ALU</b>	2	240 x 120	298 x 271	11.732 x 10.669	2.2	4.806	<b>S008000000231</b>
	<b>S 8x3 ALU</b>	3	240 x 120	298 x 402	11.732 x 15.872	3.0	6.658	<b>S008000000331</b>
	<b>S 8x4 ALU</b>	4	240 x 120	298 x 532	11.732 x 20.495	3.9	8.532	<b>S008000000431</b>
	<b>S 8x5 ALU</b>	5	240 x 120	298 x 663	11.732 x 26.102	4.7	10.385	<b>S008000000531</b>
	<b>S 8x6 ALU</b>	6	240 x 120	298 x 793	11.732 x 31.220	5.6	12.236	<b>S008000000631</b>
	<b>S 8+8x1 ALU</b>	2	240 x 120	586 x 141	23.071 x 5.551	2.5	5.467	<b>S008800000131</b>
	<b>S 8+8+8x1 ALU</b>	3	240 x 120	874 x 141	34.409 x 5.551	3.4	7.496	<b>S008880000131</b>

# S frames, technical information

S型框架, 技术信息 | S-Rahmen, technische Daten | Marcos S, información técnica |  
 Cadres S, informations techniques

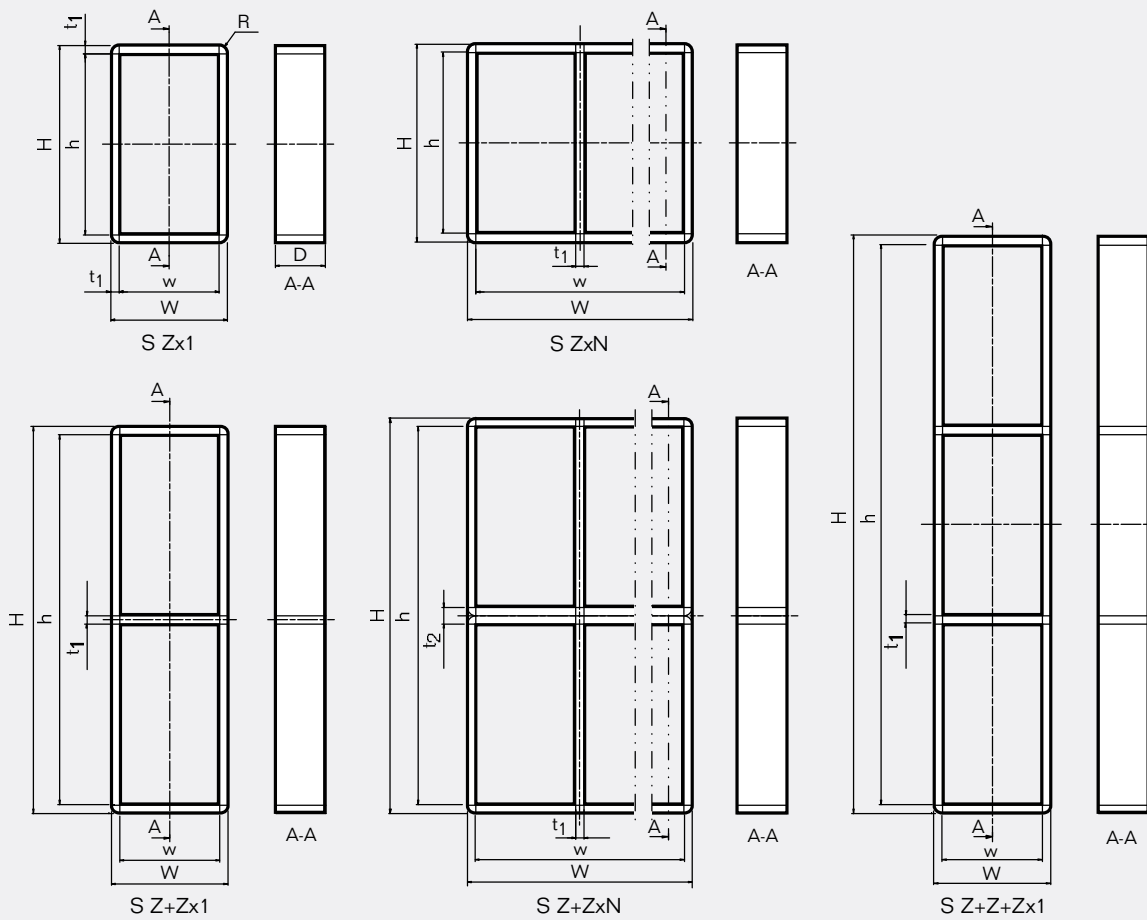

Pos	(mm)	(in)
h	H - 20	H - 0.787
w	W - 20	W - 0.787
D	60	2.362
t <sub>1</sub>	10	0.394
t <sub>2</sub>	20	0.787
R	R 10	R 0.394

Z = Frame size  
 N = Number of horizontal openings

Z = 框架型号  
 N = 水平方向的开孔数量

Z = Rahmengröße  
 N = Anzahl horizontaler Öffnungen

Z = Tamaño del marco  
 N = Número de aberturas en sentido horizontal

Z = Taille du cadre  
 N = Nombre d'alvéoles horizontales

Note: All dimensions are nominal values  
 注意: 所有的尺寸都是参考值  
 Achtung: Alle angegebenen Maße sind Nominalwerte  
 Nota: Todas las dimensiones son valores nominales  
 N.B.: toutes les dimensions sont nominales

S和SRC型框架, 焊接指南

S-, SRC-, SK- und SBTB-Rahmen, Richtlinien zum Einschweißen

Marco S, SRC, SK, SBTB, directrices de soldadura

Cadres S, SRC, SK, SBTB, instructions de soudage



**Welding sequence in bulkhead or deck**

在舱壁或甲板上的焊接顺序

Schweißfolge in Schott oder Deck

Orden secuencial de soldadura en cubiertas y mamparos

Séquence de soudage pour cloison ou pont

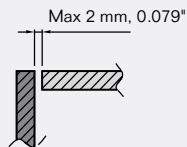
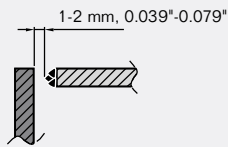
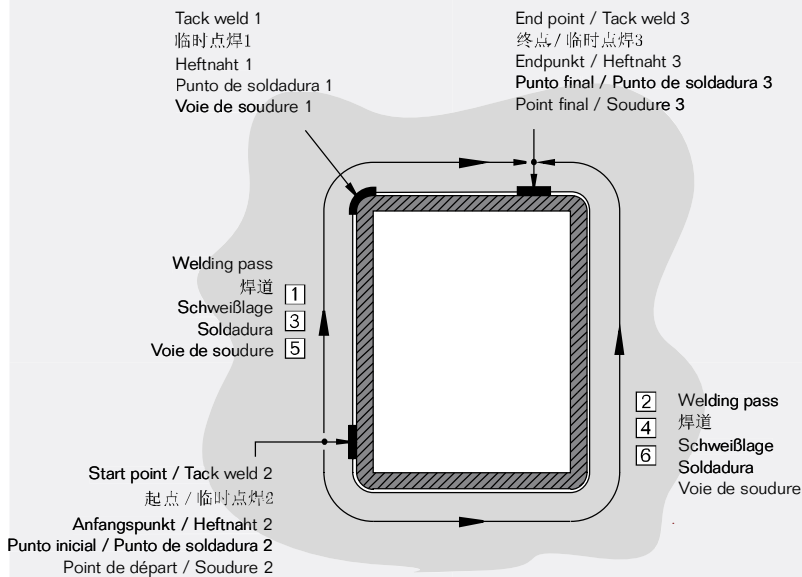

Buttering should be performed on the deck or bulkhead. Important: The root gap must be as small as possible to keep the tolerance of the openings.

对焊应在甲板或舱壁上进行。  
重要事项：根部空隙必须尽可能细小，以保持开孔公差。

Das Einschweißen sollte am Schott oder Deck vorgenommen werden. Achtung: Die Wurzelbreite muss so klein wie möglich sein damit die Toleranz der Öffnungen beibehalten wird.

Debe aplicarse un depósito preliminar en la cubierta o la mampara. Importante: El espacio de raíz debe ser lo más posible pequeño para mantener la tolerancia de las aperturas.

Le beurrage doit être fait sur le pont ou la cloison. Important: L'espace autorisé doit être aussi petit que possible afin de conserver les tolérances des ouvertures.

Max root gap for fillet joint.

角焊缝的最大容许根部间隙

Max. Wurzelbreite der Kehlnaht.

Espacio de raíz máx. permitido por la junta de solapa

Espace max. autorisé pour le cordon de soudure

Min. space for stayplates  
为隔层板预留的最小空间  
Mind. Raum für Ankerscheiben  
Espacio mín. para las placas de separación  
Espace min. pour les plaques de maintien

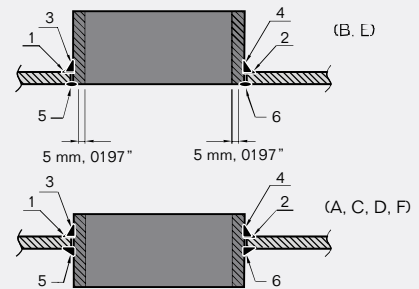

The examples depict two passes fillet weld.

描述两道角焊缝的多个实例。

Die Beispiele stellen zwei Lagen einer Kehlnaht dar.

Los ejemplos muestran dos pasamuros con soldadura de solapa.

Les exemples décrivent deux voies pour le cordon de soudure.

Important: Weld pass no. 5-6 are not to be started until welding no. 1-4 are completed and the temperature of welding pass no.1-4 has cooled down to min. pre-heat temperature.

重要事项：在1~4焊道焊接完成且温度降至最低预热温度后才可开始焊接5~6焊道。

Wichtig: es darf nicht mit dem Schweißen der Schweißlagen Nr. 5-6 begonnen werden, bevor nicht die Schweißlagen Nr. 1-4 beendet und die Temperatur mind. auf die Vorwärmtemperatur abgekühlt ist.

Importante: Las soldaduras nº 5-6 no deben comenzarse hasta que no se hayan completado las soldaduras nº 1-4 y que la temperatura de las soldaduras no se haya enfriado hasta la temperatura de precalentamiento mínima.

Important: ne pas commencer les soudures 5-6 avant que celles numérotées 1 à 4 n'aient été définitivement terminées et leurs températures redescendues au minimum à la température de préchauffage

# S, SRC, SK and SBTB frame, welding guidelines



S和SRC型框架，焊接指南

S-, SRC-, SK- und SBTB-Rahmen, Richtlinien zum Einschweißen

Marco S, SRC, SK, SBTB, directrices de soldadura

Cadres S, SRC, SK, SBTB, instructions de soudage



Fillet weld / 角焊缝 / <b>Kehlnaht</b> / Soldadura en ángulo / Tailles des filets – weld sizes / 焊缝尺寸 / Schweißnahtdicke / tamaños de soldadura / cordons de soudure								
T1 (Frame / 型框架 / Rahmen / Marco / Cadre)	T2 (Bulkhead/Deck / 舱壁/甲板 / Schott/Deck / Mamparo/Cubierta / Cloison/Pont)	Fillet weld - weld sizes / 角焊缝-焊缝尺寸 / Kehlnaht - Schweißnahtdicke / Soldadura en ángulo - tamaños de soldadura / Tailles des filets/cordons de soudure	Welding pass / 焊道 / Schweißblage / Soldadura / Voie de soudure					
			1	2	3	4	5	6
10	>=8	a6	X	X	X	X	X	X
10	>=7	a4	X	X			X	X

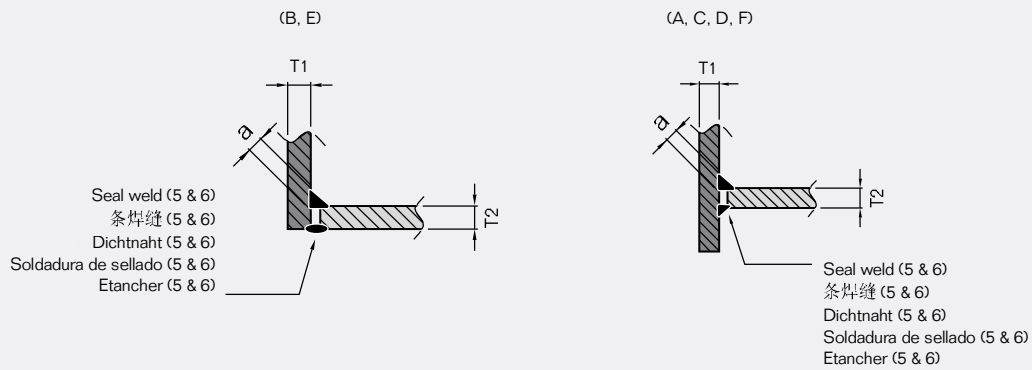

## Possible positions

可安装的位置  
Mögliche Positionen  
Posiciones posibles  
Positions possibles

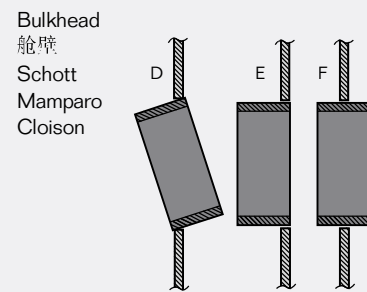
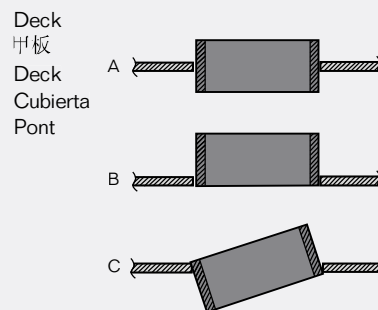

S和SRC型框架，焊接指南

S-, SRC-, SK- und SBTB-Rahmen, Richtlinien zum Einschweißen

Marco S, SRC, SK, SBTB, directrices de soldadura

Cadres S, SRC, SK, SBTB, instructions de soudage



## GB

Mild steel welding, pre-heat temperature

Combined thickness (mm)/(in) T1+T2	Minimum pre-heat temperature
<50/1.969	10° C, 50° F
>50/1.969<80/3.150	50° C, 122° F

Aluminum welding, pre-heat temperature

Combined thickness (mm)/(in) T1+T2	Minimum pre-heat temperature
<25/0.984	10° C, 50° F
>25/0.984<50/1.969	50° C, 122° F

Stainless steel welding, no pre-heat

## CN

低碳钢焊接，预热温度

组合厚度 (毫米)/(英寸) T1+T2	最低预热温度
<50/1.969	10° C, 50° F
>50/1.969<80/3.150	50° C, 122° F

铝材的焊接，预热温度

组合厚度 (毫米)/(英寸) T1+T2	最低预热温度
<25/0.984	10° C, 50° F
>25/0.984<50/1.969	50° C, 122° F

不锈钢焊接，无预热温度

## DE

Schweißen von Baustahl, Vorwärmtemperatur

Kombinierte Dicke (mm)/(in.) T1+T2	Mindestvorwärmtemperatur
<50/1.969	10° C, 50° F
>50/1.969<80/3.150	50° C, 122° F

Schweißen von Aluminium, Vorwärmtemperatur

Kombinierte Dicke (mm)/(in.) T1+T2	Mindestvorwärmtemperatur
<25/0.984	10° C, 50° F
>25/0.984<50/1.969	50° C, 122° F

Schweißen von Edelstahl, ohne Vorwärmen

## ES

Soldadura de acero dulce, temperatura de precalentamiento

Grosor combinado (mm)/(pulgadas) T1+T2	Temperatura de precalentamiento mínima
<50/1.969	10° C, 50° F
>50/1.969<80/3.150	50° C, 122° F

Soldadura de aluminio, temperatura de precalentamiento.

Grosor combinado (mm)/(pulgadas) T1+T2	Temperatura de precalentamiento mínima
<25/0.984	10° C, 50° F
>25/0.984<50/1.969	50° C, 122° F

Soldadura de acero inoxidable, sin precalentamiento

## FR

Soudage de l'acier doux, température de préchauffage

Epaisseur cumulée (mm)/(pouces) T1+T2	Température minimale de préchauffage
<50/1.969	10° C, 50° F
>50/1.969<80/3.150	50° C, 122° F

Soudage de l'aluminium, température de préchauffage

Epaisseur cumulée (mm)/(pouces) T1+T2	Température minimale de préchauffage
<25/0.984	10° C, 50° F
>25/0.984<50/1.969	50° C, 122° F

Soudure inox, pas de préchauffage

## S frame, aperture dimensions for welded installations

S型框架，用于焊接安装的孔径

S-Rahmen, Öffnungsabmessungen (Ausbrand)

Marcos S, Dimensiones del hueco para instalaciones soldadas

Cadres S, dimensions d'ouverture pour des installations soudées



CN	高度公差 ± 1 mm, ±0.039" 宽度方向上为一个 一个开孔 (毫米)   (英寸)   (毫米)   (英寸)				宽度公差 ± 1 mm, ±0.039" x1   x2   x3   x4   x5   x6   x7   x8   x9   x10 (毫米) / (英寸)									
	Rahmen				x1	x2	x3	x4	x5	x6	x7	x8	x9	x10
DE	Höhentoleranz ± 1 mm, ±0.039" 1 Öffnung in der Breite (mm)   (in.)   >1 Öffnung in der Breite (mm)   (in.)				Breitentoleranz ± 1 mm, ±0.039" x1   x2   x3   x4   x5   x6   x7   x8   x9   x10 (mm)/(in.)									
	Rahmen				x1	x2	x3	x4	x5	x6	x7	x8	x9	x10
ES	Tolerancia en altura ± 1 mm, ±0.039" 1 apertura a lo ancho (mm)   (pulgadas)   >1 apertura a lo ancho (mm)   (pulgadas)				Tolerancia en anchura ± 1 mm, ±0.039" x1   x2   x3   x4   x5   x6   x7   x8   x9   x10 (mm)/(pulgadas)									
	Marco				x1	x2	x3	x4	x5	x6	x7	x8	x9	x10
FR	Tolérance en hauteur ± 1 mm, ±0.039" 1 ouverture en largeur (mm)   (pouces)   >1 ouverture en largeur (mm)   (pouces)				Tolérance en largeur ± 1 mm, ±0.039" x1   x2   x3   x4   x5   x6   x7   x8   x9   x10 (mm)/(pouces)									
	Marco				x1	x2	x3	x4	x5	x6	x7	x8	x9	x10
GB	Height tolerance ± 1 mm, ±0.039" 1 opening in width (mm)   (in.)   >1 opening in width (mm)   (in.)				Width tolerance ± 1 mm, ±0.039" x1   x2   x3   x4   x5   x6   x7   x8   x9   x10 (mm)/(in)									
	Frame				x1	x2	x3	x4	x5	x6	x7	x8	x9	x10
S 1	123	4.843	-	-	82	-	-	-	-	-	-	-	-	-
					3.228									
S 2	123	4.843	123	4.409	143	273	404	534	665	795	926	1056	1187	1317
S 2+2	234	9.213	244	9.606	5.630	10.748	15.906	21.024	26.181	31.299	36.457	41.575	46.732	51.850
S 2+2+2	345	13.583	365	14.370										
S 3	182	7.165	-	-	82	-	-	-	-	-	-	-	-	-
					3.228									
S 4	182	7.165	182	7.165	143	273	404	534	665	795	926	1056	1187	1317
S 4+4	351	13.819	361	14.213	5.630	10.748	15.906	21.024	26.181	31.299	36.457	41.575	46.732	51.850
S 4+4+4	521	20.512	541	21.299										
S 5	240	9.449	-	-	82	-	-	-	-	-	-	-	-	-
					3.228									
S 6	240	9.449	240	9.449	143	273	404	534	665	795	926	1056	1187	1317
S 6+6	468	18.425	478	18.819	5.630	10.748	15.906	21.024	26.181	31.299	36.457	41.575	46.732	51.850
S 6+6+6	696	27.402	716	28.189										
S 8	300	11.811	300	11.811	143	273	404	534	665	795	926	1056	1187	1317
S 8+8	588	23.150	598	23.543	5.630	10.748	15.906	21.024	26.181	31.299	36.457	41.575	46.732	51.850
S 8+8+8	876	34.488	896	35.276										

Theoretically recommended dimensions / 理论参考尺寸 / Empfohlene Maße / Dimensiones teóricas recomendadas / Dimensions théoriques recommandées